

HT-9534

ASSEMBLY, HITCH RECEIVER
2020-UP POLARIS SCRAMBLER XP 1000

MBRP®

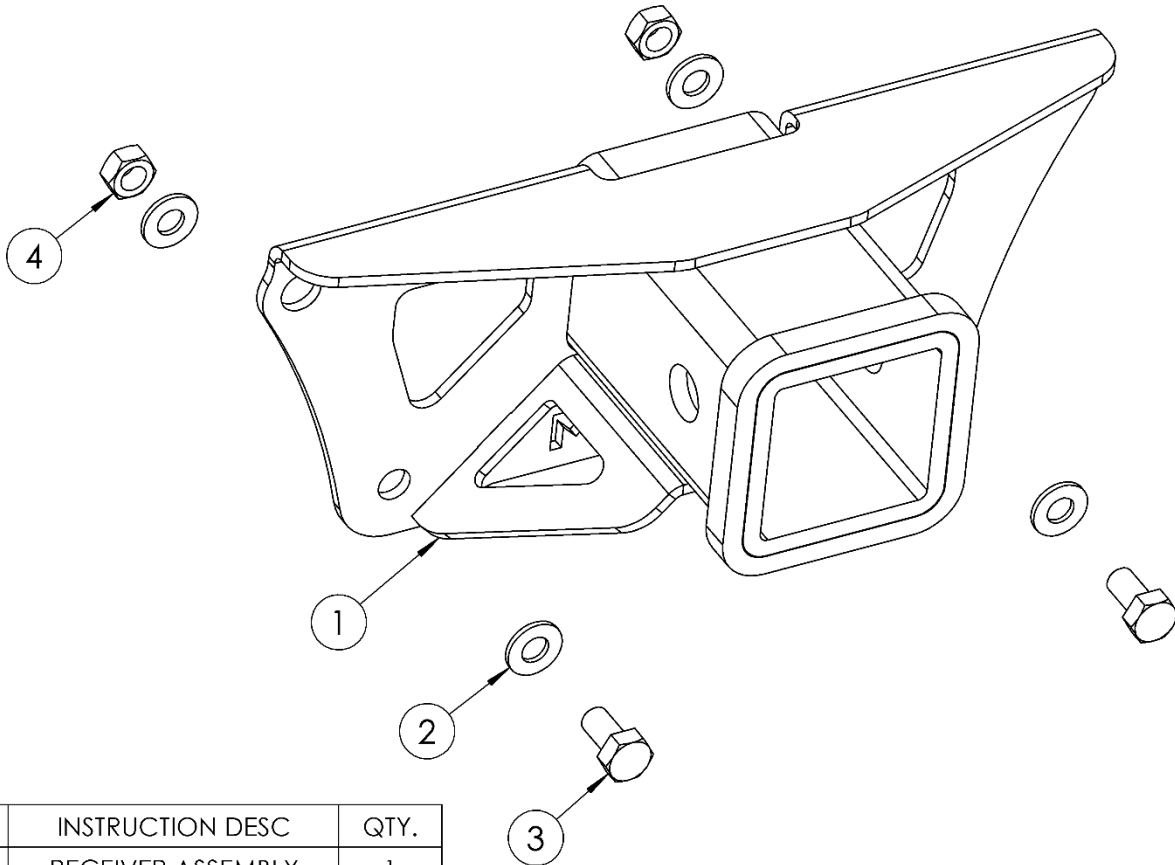

ITEM NO.	INSTRUCTION DESC	QTY.
1	RECEIVER ASSEMBLY	1
2	M8 WASHER	4
3	M8 HEX BOLT	2
4	M8 NUT	2

Refer to this LOT NUMBER when contacting customer service: _____

PLEASE READ BEFORE STARTING INSTALLATION

While MBRP has made every effort to ensure that all components of this system are of superior quality and properly packaged, it is the installer's responsibility to ensure the following before removal of the factory exhaust:

- that ALL components shown above are present.
- that ALL mating components fit together.
- that there are no damaged components.
- that the system you have purchased is appropriate for your vehicle year, model and configuration.
- that the system will not interfere with any modifications previously installed or planned.
- that you have read and understand these instructions.

If you have any questions or are uncertain about any aspect of the installation of this system to your vehicle please contact your dealer before commencing installation.

MBRP

Installation of **MBRP** Hitch Receiver

1. Remove the nut and washer from the left and right rear upper control arm mounts. Keep the hardware for reinstallation.
2. Position the **Receiver Assembly** onto the vehicle frame with the control arm mounting bolts going through the upper holes of the **Receiver Assembly**.
3. Reinstall the factory washers and nuts to the control arm mounting bolts, but do not fully tighten them yet.
4. Align the bottom holes of the **Receiver Assembly** with the holes in the rear plate of the vehicle frame, then install the provided **M8 Hardware** as shown on the cover sheet.
Refer to Figure 1 and Cover Sheet. Do not fully tighten yet.
5. Fully tighten the control arm nuts to 37ft-lbs (50Nm), then tighten the **M8 Hardware** (19ft-lbs/25Nm).



Figure 1

Congratulations! Your **MBRP** Hitch Receiver install is complete.
We know you will enjoy your purchase!