

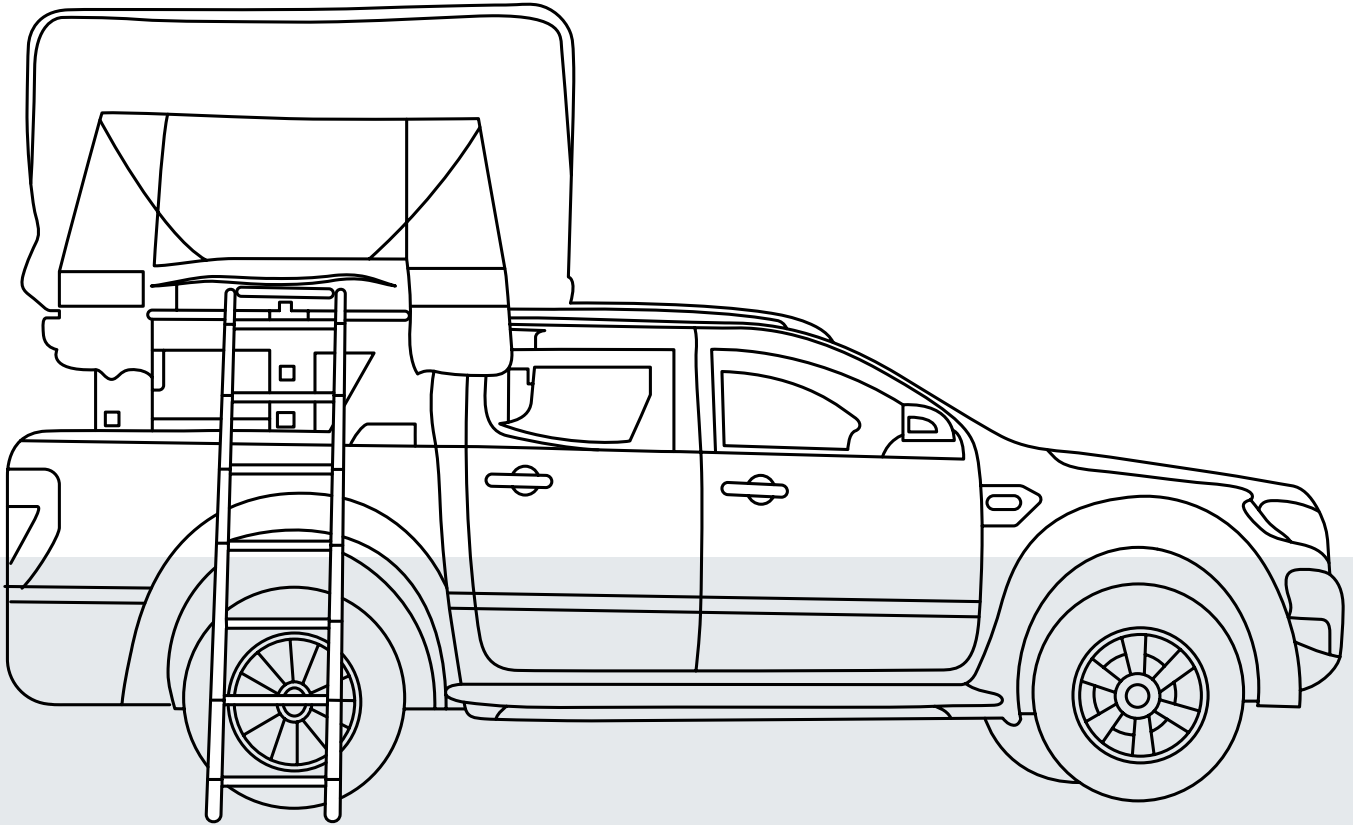

HD Bundu Hard Shell Roof Top Tent



**CAREFULLY READ INSTRUCTIONS
PRIOR TO THE FIRST USE OF THE
HD BUNDU ROOF TOP TENT**

GET TO KNOW YOUR ROOF TOP TENT

We recommend you check all parts are included prior to first use.

Bill of Material

1x Ladder

1x Lantern

4x Top Bracket

4x Bottom Bracket

8x Screws

8x Nuts

PREPARATION FOR INSTALLATION

1

Have two people stand at the front of the roof tent, and two people at the back.

Grab the panel on the bottom of the roof top tent and lift up to your waist.

Lift the roof tent up to your shoulders, and then above your head.

Gently slide the roof tent onto your cross bars.

Make sure the roof tent is centered.

NOTE: It is easiest to mount the roof tent from the side of your vehicle, not from the front or the back.

When mounting the roof top tent on your vehicle, make sure that each bracket is securely fastened, failure to do so could cause damage, injury, or even death.

Apply lubricant to bolts and nuts before tightening to reduce the risk of thread galling.

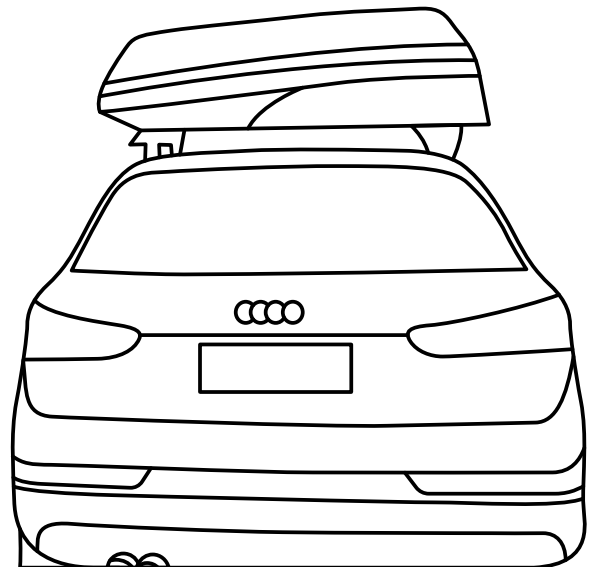

HD Bundu Hard Shell

SET-UP & CARE INSTRUCTIONS

18389902 HD Bundu 2 Hard Shell Roof Top Tent
18389904 HD Bundu 4 Hard Shell Roof Top Tent

2

1. Take the top bracket and insert two bolts according to the width of your cross bars.

2. Insert top bracket with the two bolts.

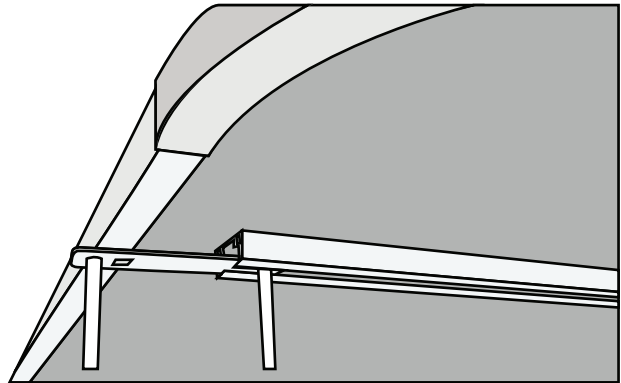

3. Have one person lift the roof tent, while another person slides the piece over the cross bar, so that one bolt is on each side of the cross bar.

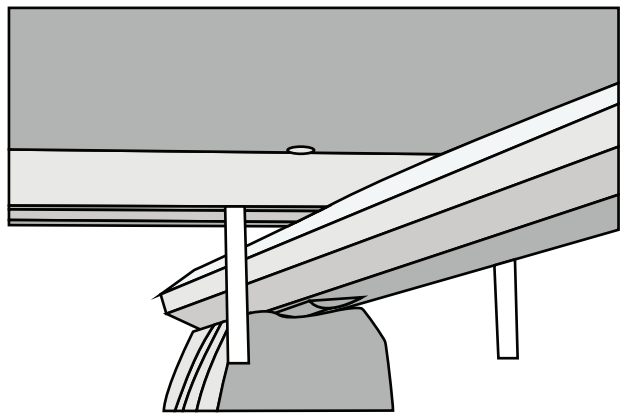

4. Take the bottom bracket and fit it under your cross bar so that the bolts go through it.

5. Attach one nut on each bolt and tighten them using a 13mm spanner.

IMPORTANT: Apply lubricant to the bolts and nuts before tightening to prevent thread galling.

6. Tighten the nuts until the bottom bracket starts to bend slightly. Do NOT keep tightening after it has already started to bend as this will make it difficult to mount again in the future.

7. Repeat the procedure for the remaining 3 brackets.

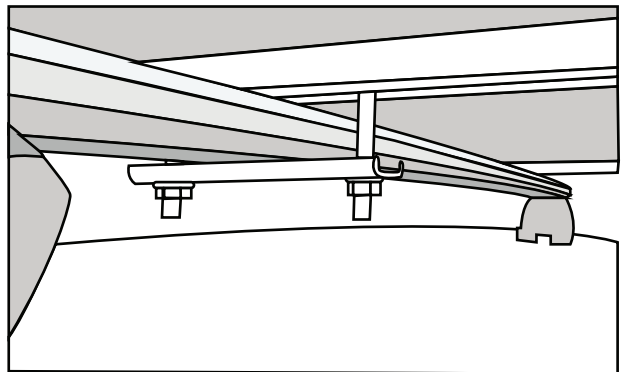

NOTE: Check that the roof tent is securely attached after a short distance, and thereafter at regular intervals. Tighten the mounting brackets whenever necessary.

HD Bundu Hard Shell

SET-UP & CARE INSTRUCTIONS

18389902 HD Bundu 2 Hard Shell Roof Top Tent
18389904 HD Bundu 4 Hard Shell Roof Top Tent

3

1. Unlock the hardshell locks (or unfasten straps) and pull down the metal case to release the strap.

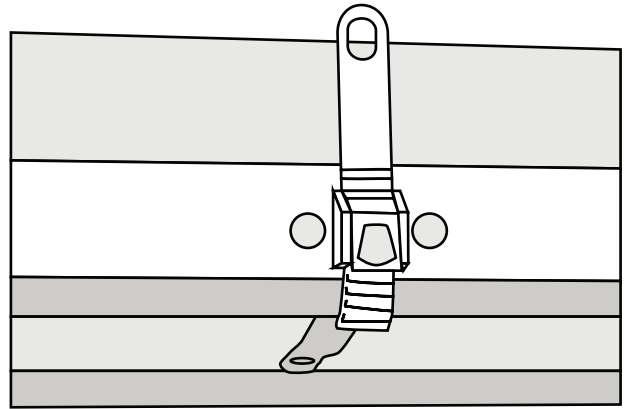

2. With one hand, push up the hard shell. The gas struts will allow it to open on its own.

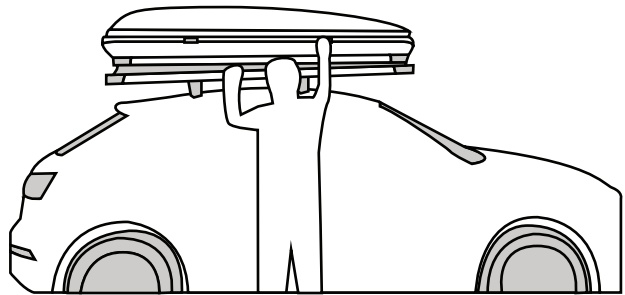

3. Once the top has fully opened, reach up and grab the base of the ladder.

4. Pull the ladder towards you, allowing it to extend completely.
NOTE: when you first use the roof tent, you will need to undo the velcro strap on the ladder)

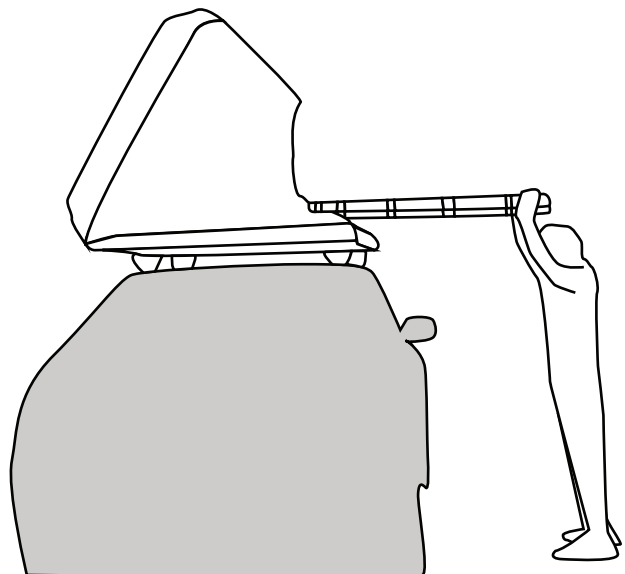

5. Push down on the ladder, as it acts as a lever and lowers the extension floor.

6. After the extension floor has been lowered, securely install the ladder.

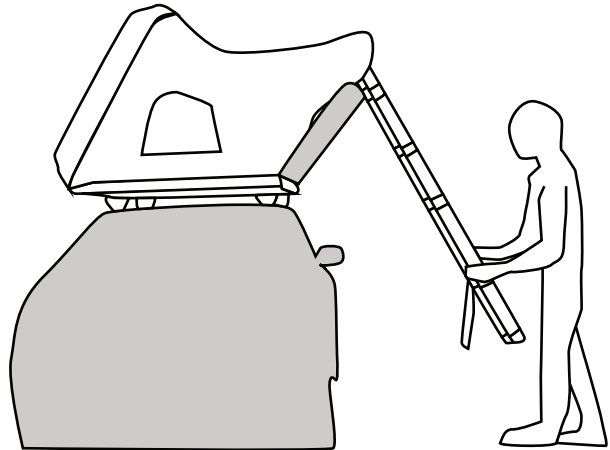

INSTALLING THE LADDER

4

The ladder acts as the support for the extension panel. Always make sure the ladder is firmly planted in the ground, and each step is securely locked before going up the ladder.

Make sure the base of the ladder is placed on even, solid ground. If not, move your vehicle to another spot. Do NOT install the ladder on uneven ground, or on rocks, sand, or mud.

Place the ladder at an approximate 70° angle as pictured. Make sure it is firmly planted in the ground.

The ladder should be able to offer support to the extension panel and the tent's occupants. The main panel (floor) and extension panel should be horizontal, with a small space between the two panels (the extension panel should be lifted up slightly higher than the main panel)

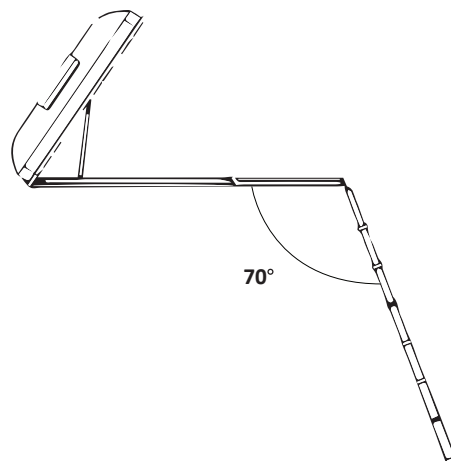
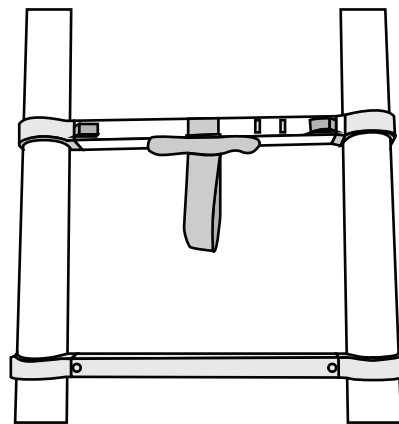

Correct Installation:

The ladder should **NOT** be over-extended as it does not offer enough support, and it should not be too vertical either.

After the ladder has been securely installed, please follow the directions below while going up and down the ladder:

1. Grab the sides of the ladder with both hands at all times.
2. Take one step at a time.
3. **NEVER** step on the top 2 steps when going up or down the ladder

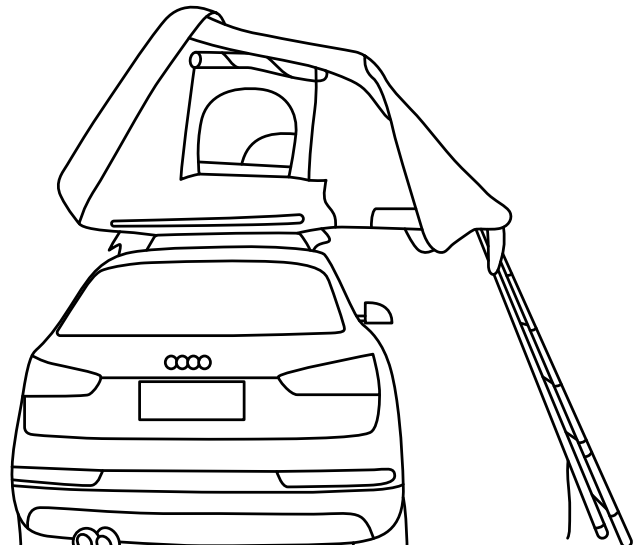

ERECTING THE CANOPY

5

The canopy should be erected using the two steel rods included with your roof top tent.

1. Climb half-way up the ladder, take one rod and insert the straight end into one of the holes located at the top of the ladder. The rod should be inserted gently until you hear a "click" sound, and the hook at the top end of the rod should be facing down.

2. Hold the rod with one hand, and with the other, grab the corner of the canopy and insert the rod's hook, facing down, into the metal grommet.

3. Repeat the process on the other side of the canopy.

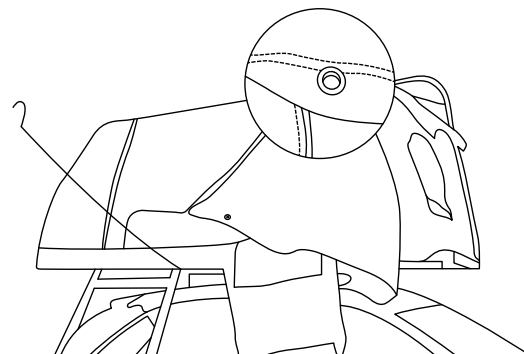
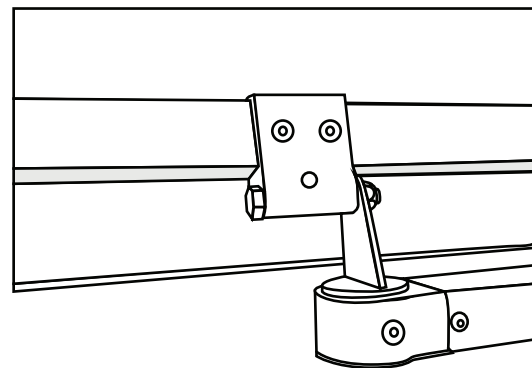
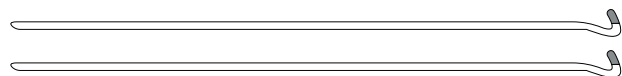

CLOSING THE HARDSHELL

6

1. Retract the ladder, starting with the top steps. Make sure to press the release buttons with your thumbs and be careful not to get any fingers caught between steps.

2. Using the ladder, push the extension panel up and then into the roof tent.

3. Reach into the roof tent to grab the black nylon strap attached to the top of the shell. Pull down on the strap to close the hard shell.

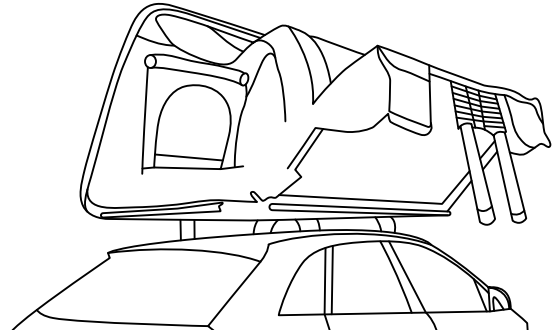

4. Tuck the excess material into the roof top tent on the front, back and side

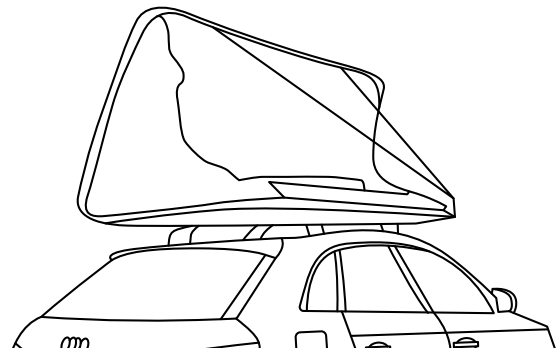

5. Pull down on the hard shell, and securely fasten the locks (or straps). Make sure the strap is tight by adjusting (twisting) the bottom U-shaped piece.

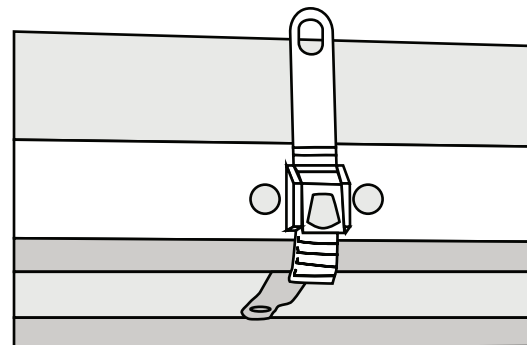
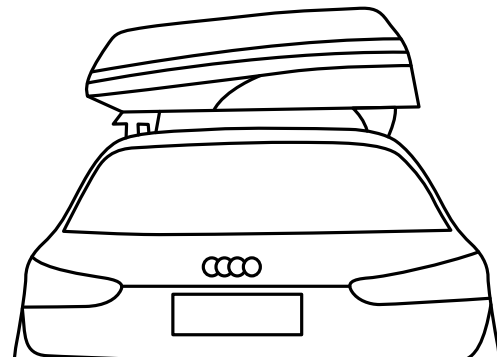

CLEANING

Clean with cold water and a soft bristle brush. Do not use soaps and detergents. Do not expose to petrol, diesel, oils or chemicals of any nature.

STORING

When storing, make sure tent is closed before the moving of your vehicle. Make sure all contents are tucked and not exposed when tent is closed. When not attached to your vehicle, make sure you store your RTT in a cool and dry area.

WARNINGS

- BEFORE CLOSING THE ROOF TOP TENT, YOU MUST UNFASTEN THE BUNGEE CORDS THAT ARE ATTACHED UNDER THE PANELS. LEAVING THE CORDS ATTACHED PUTS STRESS ON THE TENT AND MAY CAUSE THE FABRIC TO TEAR.
- IF YOU HAVE ANY BACK, KNEE OR ANY OTHER HEALTH COMPLICATIONS, DO NOT ATTEMPT TO MOUNT THE ROOF TENT ON YOUR VEHICLE
- THE CROSS BARS MUST HAVE A DYNAMIC WEIGHT LOAD OF AT LEAST 165 LBS (75 KGS) AND MUST BE AT LEAST 30" (76 CM) APART.
- THE FASTENING STRAPS KEEP YOUR ROOF TOP TENT CLOSED AND MAKE SURE IT DOES NOT OPEN WHEN DRIVING. ALWAYS MAKE SURE THAT THE HARD SHELL IS COMPLETELY CLOSED AND THE STRAPS ARE SECURELY FASTENED BEFORE DRIVING.
- IF YOU FIND IT DIFFICULT TO COMPLETELY CLOSE THE ROOF TOP TENT, IT MAY BE DUE TO EXCESS BEDDING LEFT INSIDE THE TENT. IN THIS CASE, REMOVE SOME OF THE BEDDING AND TRY AGAIN.
- THE RECOMMENDED SPEED LIMIT WHEN HAVING THE ROOF TENT ON YOUR VEHICLE IS 70 MPH (110KM/H). DRIVING SPEED SHOULD ALWAYS BE ADJUSTED ACCORDING TO THE CURRENT DRIVING

CONDITIONS, SUCH AS ROAD TYPE AND QUALITY, WEATHER (WIND CONDITIONS, RAIN), AND APPLICABLE SPEED LIMITS. DRIVE SLOWLY ON SPEED BUMPS AND BUMPY ROADS.

- THE BUNDU HARD SHELL RTT HAS BEEN DESIGNED FOR GENERAL CAMPING USE UNDER NORMAL CONDITIONS.
- TO AVOID CHANCES OF PERSONAL INJURY AND PROPERTY DAMAGE, WE HIGHLY RECOMMEND THE MAMBA II ROOF TOP TENT SHOULD NOT BE ERECTED DURING WINDY CONDITIONS AS PERSONAL INJURY AND OR PROPERTY DAMAGE MAY OCCUR.
- DO NOT CUT OR MODIFY THE TENT OR MOUNTING ACCESSORIES.
- DO NOT EXCEED THE VEHICLE MANUFACTURER'S WEIGHT LIMITS.
- DO NOT USE DAMAGED OR EXCESSIVELY WORN PRODUCTS. CONTACT US IF YOU ARE UNSURE.
- KEEP ALL FLAMES AND HEAT SOURCES AWAY FROM THE FABRIC
- UNDER NO CIRCUMSTANCES SHOULD ANY NAKED FLAME SOURCES BE USED NEAR THE TENT, KEEP FIRES AWAY FROM THE TENT
- KEEP A LOOK OUT FOR ANY AIRBORNE BURNING EMBERS THAT MAY COME IN CONTACT WITH THE TENT. KEEP A FIRE EXTINGUISHER OR BUCKET OF WATER NEAR BY.
- DO NOT OPERATE ANY DEVICES WHICH BURN FUEL INSIDE THE TENT WHILE THE WALLS ARE ATTACHED.
- KEEP EXITS CLEAR
- KEEP AN EYE OUT FOR CHILDREN WHEN TENT IS IN USE
- STOW AWAY TENT BEFORE OPERATING VEHICLE



DO YOU NEED OUR HELP?



CUSTOMER SUPPORT 833-226-4863



SALES@OVERLANDVEHICLESYSTEMS.COM

WANT TO SHOW US YOUR RIG?
CHECK OUT OUR SOCIAL!

@overlandvehiclesystems

